

INDUSTRIAL WEIGHING SOLUTION™



24 PLUs' Direct memory key
& User-friendly keypad



Load Cell
protection screw



Pivot & Tilt indicator

ECB SERIES

Counting Scale

ECB is covering from 30kg to 250kg as 1/600,000 (internal) and 1/15,000 (external) resolution and has the various uses such as manufacturing, packing and farming industries and tool shops. Additionally, there is a big memory space for items. It will bring convenient operation & faster counting application.

- Up to 124 PLUs' storable memory space
: 24 PLUs' Direct memory key & 100 PLUs' Indirect memory space
- Ticket /Label printer (optional)
- Check-weight /Count with beep sounds



CAS

ECB SERIES | Counting Scale

SPECIFICATIONS

Model	ECB SERIES			
Max. capacity(kg)	30	75	150	250
Readability(g)	2	5	10	20
External resolution	1/15,000	1/15,000	1/15,000	1/12,500
Internal resolution	1/600,000			
Display type	LCD display (backlight)			
Weight units	kg, g, lb			
Operation temperature	0°C ~ 40°C			
Power	AC adapter DC 12V / 850mA , Rechargeable battery (6V,5Ah)			
Battery life	100hrs continuous use with 12 hrs charging time (Backlight off)			
Safe overload capacity	120% of Max.capacity			
Product size (mm)	500(W) × 720(D) × 760(H)			
Platform size (mm)	400(W) × 500(D)			

FEATURES

- 1/15,000 External resolution , 1/600,000 Internal resolution for accurate counting
- Storable PLU memory space (Unit weigh/ Tare / Item No./Address No.) : 24 PLUs' Direct key, 100 PLUs' Indirect key
- Check-weight/count function with beep sounds
- Embossed key pad for comfort pressing
- Auto power off function for power saving
- Ticket / Label printer interface
- Rechargeable battery (included)
- RS-232C interface (included)
- AC adapter (included)
- Dust protection cover (included)

Accessories

- Ticket printer (DEP-50)
- Label printer (DLP-50)



High resolution for accurate counting

1/600,000 internal and 1/15,000 external resolution are enhanced for more accurate counting. ECB counting scale is engineered for precise and high operation speed application.

3 LCD displays for counting

Weight, Unit weight and Count are clearly shown from three individual LCD displays.

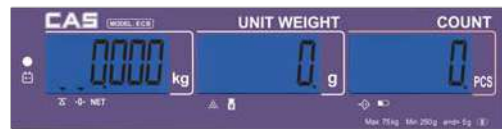

Various outputs

ECB is possible to connect with Ticket /Label printer or personal computer through RS-232C interface. Also, CAS provides the label format edit program for various applications.

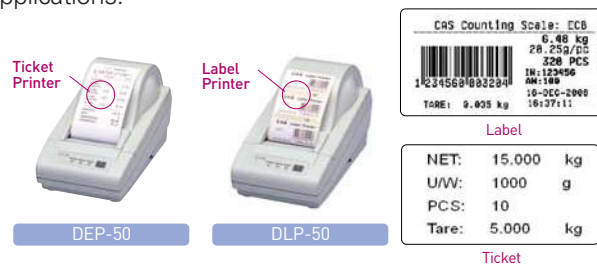

DIMENSIONS

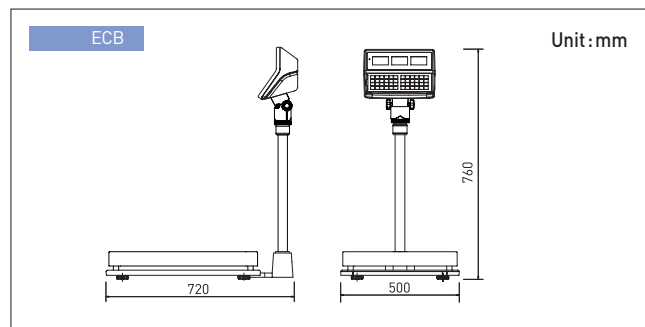

CAS

CAS BLDG., # 440-1, SUNGNAE DONG,
GANGDONG GU, SEOUL, KOREA

TEL_ 82 2 2225 3500

FAX_ 82 2 475 4668

<http://www.globalcas.com>

Specifications are subject to change for improvement without prior notice.

0-12218002