

Wireless Crane Scale

Model: MK-E85



Features:

- Seamless steel pipe enclosure for maximum protection
- Menu operation mode, calibration, saving, searching, peak hold, easy to operate
- Indicator adopts $\Sigma - \Delta$ A/D conversion technology
- Weighing data save protection in case of power off
- Battery charger with several protection modes to extend life of rechargeable battery
- Standard RS232 communication interface (optional)
- Portable design, indicator packed in portable carry case, easy to operator outdoor
- Gathering up to data records of 99 weighings, records can be sorted, searched
- Power saving mode, indicator will turn off automatically after 30 minutes with no operation
- With 32 channels optional, so 32 crane scales can operated independently in the same airplace without interface
- Crane scale battery can be use up to ± 300 hours non-stop

Accuracy Standard	According to OIML Class III
Display	LCD with backlight
Wireless Distance	Up to 200m without obstacle
Filtering	Low, medium or high selectable
Resolution	2000 to 3000 divisions standard up to 15,000 available
Zero Range	Auto/Manual setting, from 4% to 100%F.S.
Tare Range	100% F.S.
Overload Indication	100% F.S. 9e
Max. Safety Load	125% F.S.
Max. Ultimate Load	150% F.S.
Scale Battery Type	3,7V/12Ah Rechargeable Lithium-ion Battery
Indicator Battery	DC 6V/4,5Ah Rechargeable Lead-Acid battery
Battery Charger for Indicator	Input: AC100-240V 50/60Hz Output: 850mA
Operating Temperature Range	-20°C ~ +50°C
Operating Humidity	$\leq 85\%$ RH under 20°C
Radio Frequency	433MHz

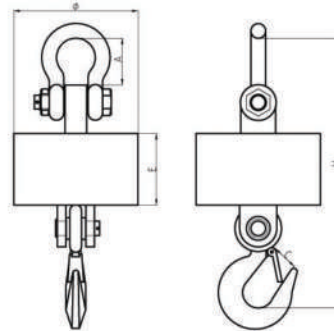

Dimensions and Specifications

Model	Cap. (kg)	Resolution (kg)	A (mm)	C (mm)	E (mm)	H(mm)	Ø(mm)	G.W.(kg)
MK-E85-1	1000	0.5	95	33	145	445	270	30
MK-E85-2	2000	1	95	33	145	445	270	30
MK-E85-3	3000	1	95	40	145	445	270	31
MK-E85-5	5000	2	120	50	155	485	298	42
MK-E85-10	10000	5	124	60	170	655	325	52
MK-E85-15	15000	5	225	70	170	855	325	72
MK-E85-20	20000	10	225	85	170	920	325	82
MK-E85-30	30000	10	260	105	200	1055	375	122